



© Premicon AG

River cruise vessel with Jastram azimuth grid thruster in the bow section and Jastram active noise reduction.

Technical features:

The thruster gear is bolted to the housing and can be mounted and dismantled during docking.

The propeller is mounted with a tight oil press fit which allows rapid mounting and dismantling during shaft seal changes.

The stainless steel ring in the propeller tip region protects the housing against cavitation damage.

The oil lubrication system with oil level sensor (to be installed by the shipyard above waterline) protects the seals against water ingress.

Options:

Impressed current cathodic protection (ICCP) instead of anodes for longer life and reduced resistance in the housing.

Active noise reduction to reduce cavitation noise.

For transverse thrusters, control & drive systems and low-noise thrusters please see our other brochures:

Azimuth Grid Thrusters



- ▶ 360° steering grid
- ▶ Reliable thruster gears
- ▶ Resistant to grounding
- ▶ Suitable for shallow water
- ▶ Low-noise operating mode

Transverse Thrusters

- ▶ 50 kW to 1650 kW
- ▶ All major classifications
- ▶ Unrivaled durable gears
- ▶ 4000 thrusters in operation
- ▶ High-performance FP propellers

Thruster Drives and Controls

- ▶ Customised systems
- ▶ All drive applications
- ▶ Specialists in FC drives
- ▶ User-friendly operation
- ▶ New builds and retrofits

Low-Noise Thrusters

- ▶ Patented technology
- ▶ Reduced cavitation noise
- ▶ Recognised mega-yacht supplier
- ▶ Resiliently mounted drive assembly
- ▶ For transverse & azimuth grid thrusters

2008/10



Jastram GmbH & Co. KG
 Billwerder Billdeich 603
 21033 Hamburg · Germany
 Tel: +49(0) 40 / 725 601 - 0
 Fax: +49(0) 40 / 725 601 - 28
 Mail: info@jastram.net
 www.jastram-group.com





The Jastram azimuth grid thruster is capable of providing highly accurate dynamic positioning, responsive steering and emergency propulsion.

Mounted flush to the bottom of the vessel, it has no protruding parts which could be damaged in shallow water. A removable grid protects the horizontally mounted propeller. Smaller parts and sand are washed through the large-volume housing.

A special propeller generates effective thrust with a high volume at a low pressure.

With the solid Jastram thruster gear, the water is pumped through the 360° rotating steering grid.

Turning the grid by up to 180° in 8 seconds, the thruster provides immediate thrust in all directions.

The prime mover can be moved by 180° around the propeller according to the given installation conditions in the hull structure.

The given thrust range is based on experience as well as calculations using the column 'Max kW' and is about 70% of the thrust of transverse thrusters. 'Max kW' may differ for requirements of classification societies.

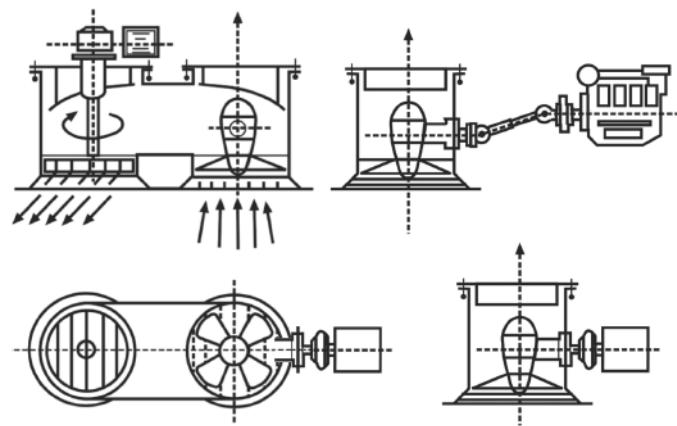

© Eidesvik Offshore ASA

Two 600kW Jastram W90 azimuth grid thrusters in the bow of the ARCOS ensure the dynamic positioning capability for cable laying and servicing in shallow water areas.

Type	Prop Ø mm	Max Input Rpm	Max kW	Max kW Diesel DP*	Thrust approx kN
W10	620	1.500 1.800	70 83		6 - 8 7 - 9
W20	840	1.500 1.800	138 165	116 140	11 - 15 12 - 17
W40	990	1.500 1.800	217 260	187 225	16 - 22 18 - 25
W50	1.000	1.500	315	315	21 - 29
W60	1.220	1.500 1.800	510 610	426 510	33 - 46 37 - 51
W90	1.600	1.500 1.800	583 700	500* 600*	43 - 60 48 - 67
W100	1.940	1.000 1.200	750 900	688* 825*	57 - 80 64 - 90



© Holyhead Towing

Ro Ro vessel with four azimuth grid thrusters for transporting Airbus A380 wings in shallow water and extremely tight river sections at high tidal ranges.

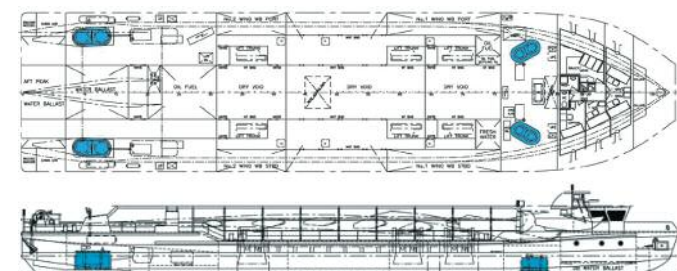

Four azimuth grid thrusters for optimum manoeuvrability have been installed in two heavy-lift barges which can be named as reference projects.